

© DEN HARTOG INDUSTRIES, INC.

Copyright. All information furnished within this document, electronic file or design correspondence is the property of Den Hartog industries, Inc. and shall not be used, disclosed to others or copied without the expressed written consent of Den Hartog Industries, Inc.

FS2600-SK

E

KEY	PART NUMBER	DESCRIPTION	QTY.
1	FS2600-SK-1	SIDE CHANNEL	2
2	FS2600-SK-2	SUPPORT CHANNEL	6
3	FS2600-SK-3	SUPPORT CHANNEL (HOLES)-LEFT	3
4	FS2600-SK-4	SUPPORT CHANNEL (HOLES)-RIGHT	3
5	FS2600-SK-5	TOP SUPPORT PLATE-SMALL	2
6	FS2600-SK-6	TOP SUPPORT PLATE-LARGE	2
7	FS2600-SK-7	TOP SUPPORT PLATE	1
8	FS2600-SK-8	SPLIT TOP SUPPORT PLATE	4
9	FS2600-SK-9	BASE SUPPORT PLATE	4
10	FS2600-SK-10	BASE SUPPORT PLATE-LARGE	4
11	FS2600-SK-11	BASE SUPPORT PLATE-SMALL	4
12	12411	5" X 5" GUSSET	8
13	13201	PLATE, POWDER COATING	2

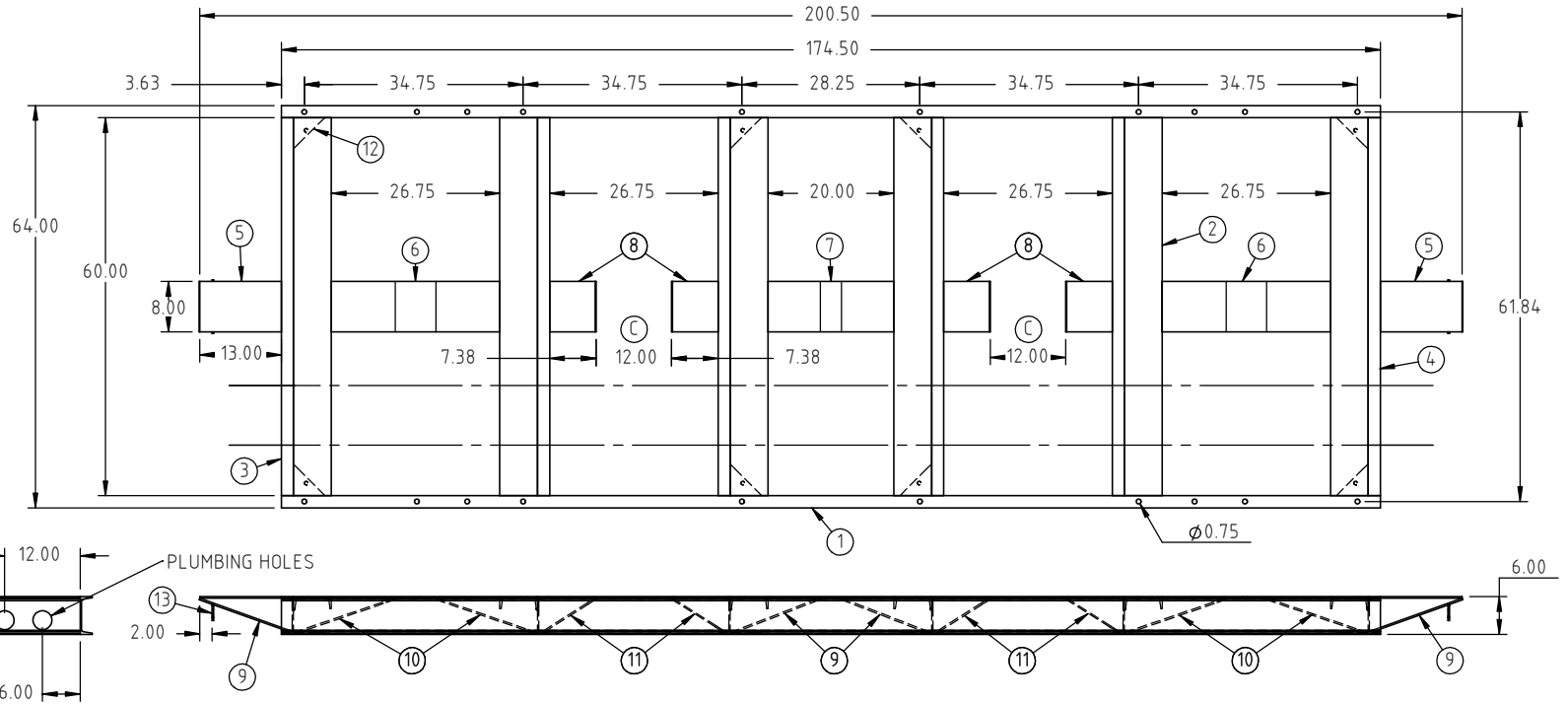

E	PRINTS 2.25 WAS 2.50, LOCATION CORRECTED, POWDER COATING PLATE ADDED, WEIGHT/FINISH ADDED	ADH 8/2/12	2465
D	TABLE ADDED TO DRAWING, DRAWING TEMPLATE UPDATED.	ADH 3/27/09	1828
C	INCREASE SUMP CLEARANCE	DHJ 11/2/07	
B	ADD GUSSETS	9/22/06	
A	ADD PLUMBING HOLES	3/29/06	
REV	DESCRIPTION	BY / DATE	CCN

DRAWN / DATE	MATERIAL
REH/01/28/02	
APPRD. / DATE	
DHJ / 1/28/01	



Den Hartog
INDUSTRIES, INC.

Acra Roto-Mold Injection Molding Blow Molding Blowjey

4010 HOSPERS DRIVE S. BOX 425, HOSPERS, IOWA 51238-0425

ALL DIMENSIONS ARE IN DECIMAL INCHES TOLERANCES UNLESS OTHERWISE SPECIFIED

POLYETHYLENE
±1% @ 68°F

METAL
DECIMAL ± .125"
FRACTION ± 1/4"
ANGLE ± 1°

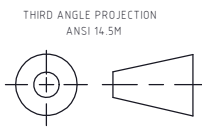

SHOT WEIGHT:

SHIPPING WEIGHT:
900.00 LBS

FINISH: POWDER COATING, BLACK TILE, 40012

NOTES:

DESCRIPTION	2600 GALLON TANK SKID	
SCALE	N.S.	PART NO. FS2600-SK

Copyright. All information furnished within this document, electronic file or design correspondence is the property of Den Hartog Industries, Inc. and shall not be used, disclosed to others or copied without the expressed written consent of Den Hartog Industries, Inc.

NOTE 1: PRESS TANK KEY (ITEM 10) INTO ONE TANK RECESS WITH LARGER DIAMETER ON ONE SIDE OF THE KEY. THIS WILL HOLD THE KEY IN PLACE DURING ASSEMBLY

KEY	PART NUMBER	DESCRIPTION	QTY.
1	FS1295-62FS/FW	TANK BODY	2
2	FS2600-SK	SKID WELDMENT	1
3	FS062-HPS	FS, HOOP 62"	6
4	FS062-HPC	HOOP WELDMENT	2
5	FS2600-CP	CONNECT PLATE	1
6	FS10026	RH RETAINER	2
7	10528	16" LID ASSY.	2
8	10508	2" FITTING ASSY.	2
9	J.625X8.000	J-BOLT, 5/8" X 8" PLATED	12
10	FS24-D	TANK KEY	1
11	10938	NUT, 5/8" NYLOK GR 2 ZINC	12
12	11092	BOLT, 3/8" X 1-1/5" GR 5 ZINC	4
13	SJ10937	WASHER, 3/8" FLAT ZINC	8
14	SJ10940	NUT, 3/8" NYLOK GR 2 ZINC	4
15	10126	NUT, 1/2"-13 HEX GR 2 ZINC	8
16	10323	WASHER, 1/2" FLAT ZINC	16
17	10695	BOLT, 1/2" X 1-1/2" GR 5 ZINC	8
18	FS10027	LH RETAINER	2

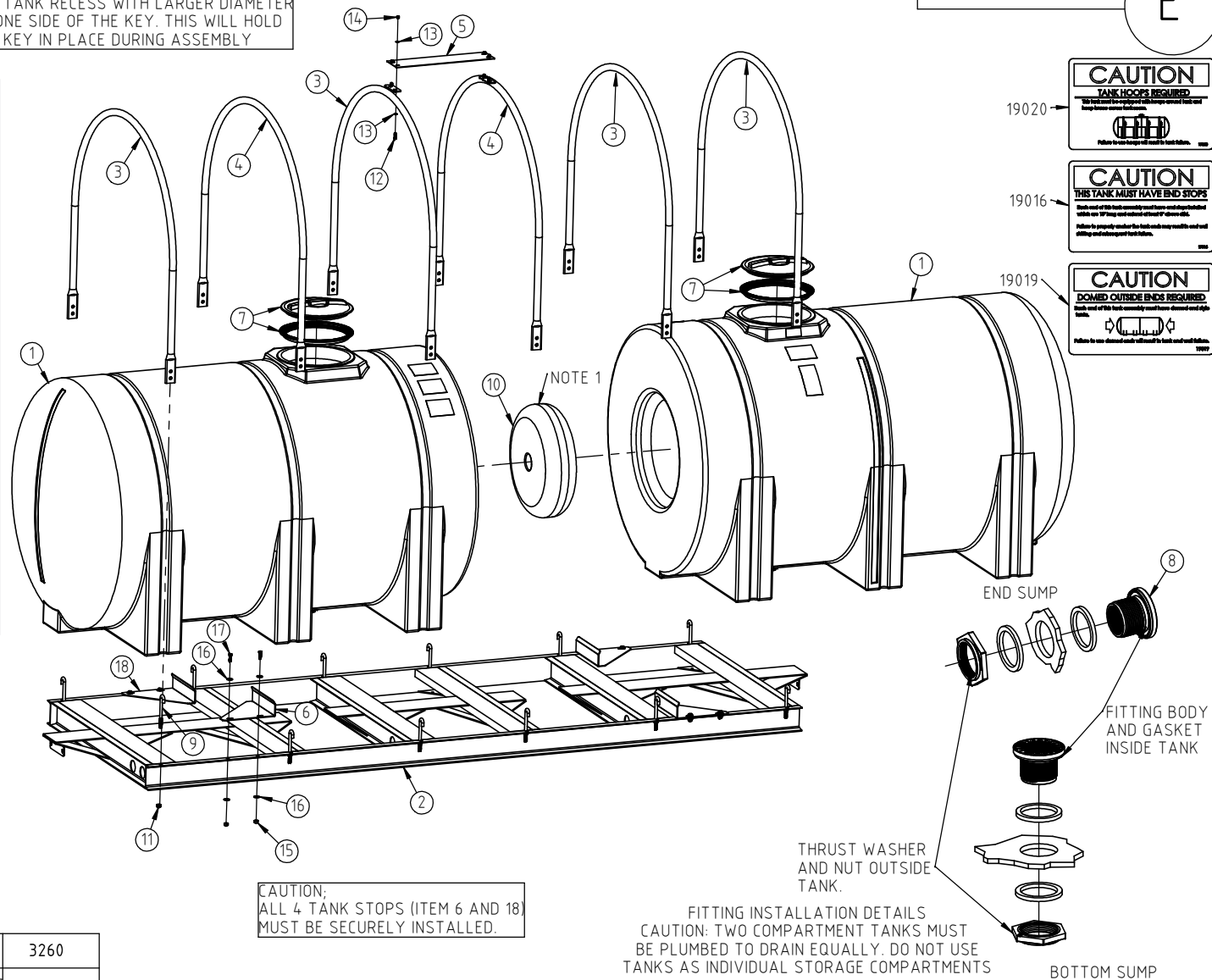

CAUTION
TANK HOOPS REQUIRED
Do not install hoops until tank is secured to skid.

CAUTION
THIS TANK MUST HAVE END STOPS
Each end of the tank assembly must have end stops installed within 10" of the tank assembly end. Failure to properly install the end stops may result in tank end shifting and subsequent tank failure.

CAUTION
DOMED OUTSIDE ENDS REQUIRED
Failure to use domed ends will result in tank end failure.

CAUTION,
ALL 4 TANK STOPS (ITEM 6 AND 18)
MUST BE SECURELY INSTALLED.

FITTING INSTALLATION DETAILS
CAUTION: TWO COMPARTMENT TANKS MUST
BE PLUMBED TO DRAIN EQUALLY. DO NOT USE
TANKS AS INDIVIDUAL STORAGE COMPARTMENTS

E	BAFFLE FEATURES REMOVED. DRAWING TEMPLATE/LAYOUT UPDATED.	ADH 7/15/16	3260
D	REMOVE TOLERANCE	GWC 3/19/07	
C	CHANGE TO FM PART #	11/6/06	
B	ADD CAUTION NOTE	11/2/06	
A	LID POSITION CORRECTED	10/04/01	
REV	DESCRIPTION	BY / DATE	CCN

DRAWN / DATE	MATERIAL
REH 8/08/01	
APPRD. / DATE	
REH 8/08/01	
SHOT WEIGHT:	NOTES:
SHIPPING WEIGHT:	
FINISH:	

ALL DIMENSIONS ARE IN DECIMAL INCHES TOLERANCES UNLESS OTHERWISE SPECIFIED

POLYETHYLENE METAL
DECIMAL ± .125"
FRACTION ± 1/4"
ANGLE ± 1°

THIRD ANGLE PROJECTION
ANSI 14.5M

Den Hartog
INDUSTRIES, INC.

Ace Roto-Mold Injection Molding Blow Molding Sowjoy

4010 HOSPERS DRIVE S. BOX 425, HOSPERS, IOWA 51238-0425

DESCRIPTION ACE 2600 GALLON TANK SKID ASSEMBLY AND PARTS

SCALE N.S. PART NO. FS2600-2W / FM2600-2S

Copyright. All information furnished within this document, electronic file or design correspondence is the property of Den Hartog industries, Inc. and shall not be used, disclosed to others or copied without the expressed written consent of Den Hartog Industries, Inc.

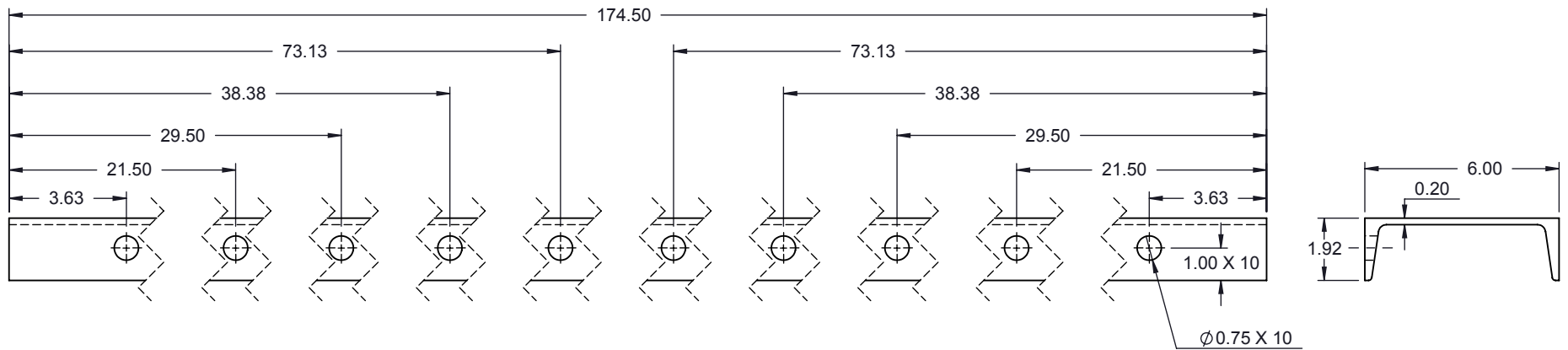

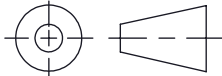
				DRAWN / DATE ADH 9/25/07	MATERIAL 1.) CHANNEL, 6", MILD STEEL	 <p>Den Hartog INDUSTRIES, INC.</p> <p>Ace Roto-Mold Injection Molding Blow Molding Sowjoy</p> <p>4010 HOSPERS DRIVE S. BOX 425, HOSPERS, IOWA 51238-0421</p>
				APPRD. / DATE REH 3/12/09	2.) CUT FROM C06X82	
REV	DESCRIPTION	BY / DATE	CCN	SHOT WEIGHT:	NOTES:	DESCRIPTION FS, 2600 GALLON TANK SKID, 6" SIDE CHANNEL
ALL DIMENSIONS ARE IN DECIMAL INCHES TOLERANCES UNLESS OTHERWISE SPECIFIED		THIRD ANGLE PROJECTION ANSI 14.5M		SHIPPING WEIGHT:		SCALE N.S.
POLYETHYLENE ±1% @ 68°F				FINISH:		PART NO. FS2600-SK-1
METAL DECIMAL ± .125" FRACTION ± 1/4" ANGLE ± 1°						

Copyright. All information furnished within this document, electronic file or design correspondence is the property of Den Hartog industries, Inc. and shall not be used, disclosed to others or copied without the expressed written consent of Den Hartog Industries, Inc.

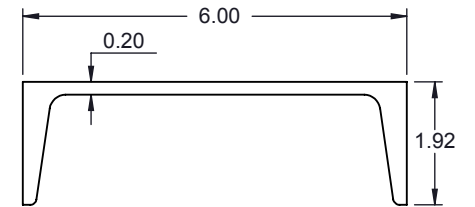
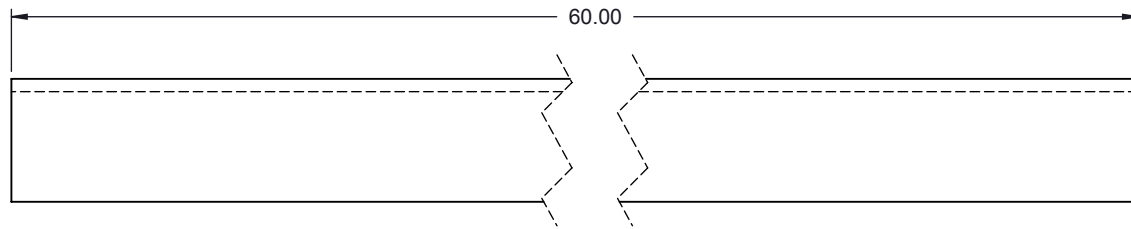

				DRAWN / DATE ADH 9/25/07	MATERIAL 1.) CHANNEL, 6", MILD STEEL
				APPRD. / DATE REH 3/12/09	2.) CUT FROM C06X82
REV	DESCRIPTION	BY / DATE	CCN	SHOT WEIGHT:	NOTES:
	ALL DIMENSIONS ARE IN DECIMAL INCHES TOLERANCES UNLESS OTHERWISE SPECIFIED			THIRD ANGLE PROJECTION ANSI 14.5M	
	POLYETHYLENE ±1% @ 68°F			METAL DECIMAL ± .125" FRACTION ± 1/4" ANGLE ± 1°	
				SHIPPING WEIGHT:	
				FINISH:	



Den Hartog
INDUSTRIES, INC.

Ace Roto-Mold Injection Molding Blow Molding Sowjoy

4010 HOSPERS DRIVE S. BOX 425, HOSPERS, IOWA 51238-0421

DESCRIPTION FS, 2600 GALLON TANK SKID, 6" SUPPORT CHANNEL

SCALE N.S.

PART NO. FS2600-SK-2

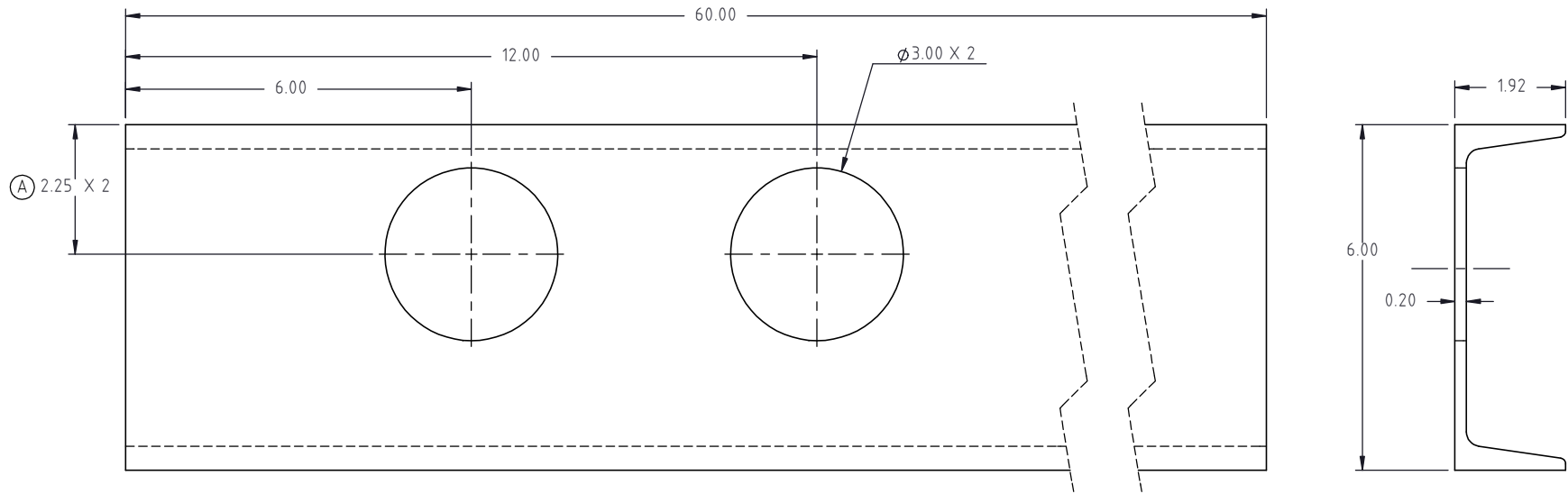

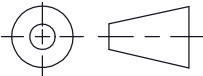
				DRAWN / DATE ADH 9/25/07	MATERIAL 1.) CHANNEL, 6", MILD STEEL 2.) CUT FROM C06X82	 <p>Den Hartog INDUSTRIES, INC.</p> <p><i>Acro-Roto-Mold Injection Molding Blow Molding Blow-Jet</i></p> <p>4010 HOSPERS DRIVE S. BOX 425, HOSPERS, IOWA 51238-0421</p>
A	2.25" WAS 2.50", DRAWING TEMPLATE UPDATED	ADH 8/2/12	2465	APPRD. / DATE REH 3/12/09		
REV	DESCRIPTION	BY / DATE	CCN			
ALL DIMENSIONS ARE IN DECIMAL INCHES TOLERANCES UNLESS OTHERWISE SPECIFIED POLYETHYLENE ±1% @ 68°F		THIRD ANGLE PROJECTION ANSI 14.5M 		SHOT WEIGHT:	NOTES:	DESCRIPTION FS, 2600 GALLON TANK SKID, 6" SUPPORT CHANNEL (HOLE)-LEFT
METAL DECIMAL ± .125" FRACTION ± 1/4" ANGLE ± 1°				SHIPPING WEIGHT:		SCALE N.S.
				FINISH:		

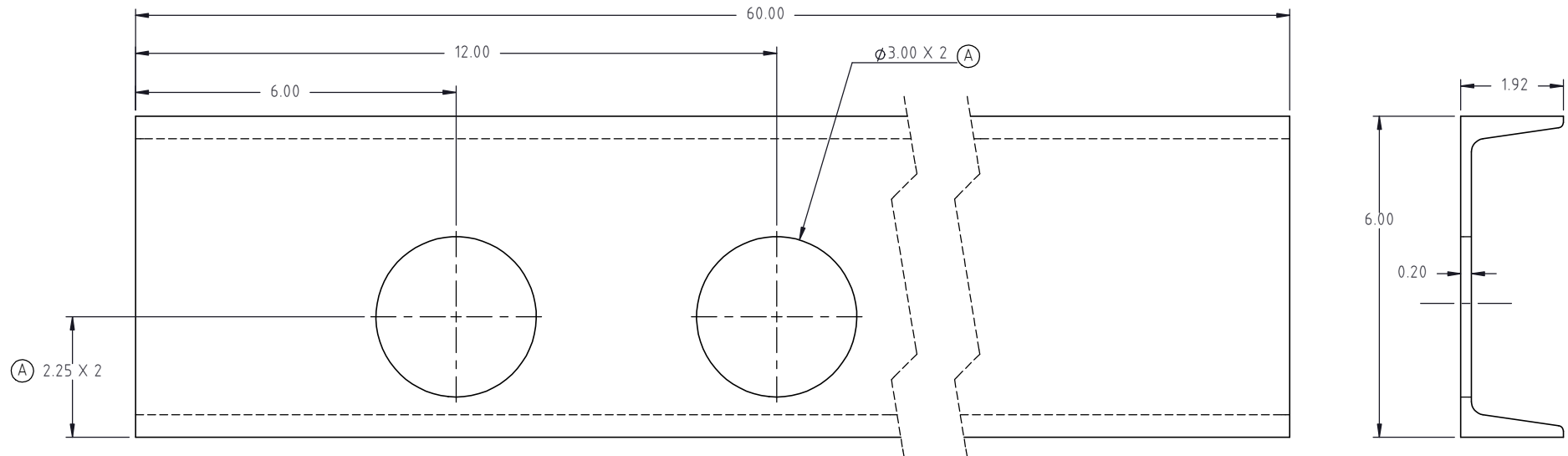

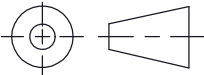
				DRAWN / DATE ADH 9/25/07	MATERIAL 1.) CHANNEL, 6", MILD STEEL	 <p>Den Hartog INDUSTRIES, INC.</p> <p><i>Acra Roto-Mold Injection Molding Blow Molding Sowjoy</i></p> <p>4010 HOSPERS DRIVE S. BOX 425, HOSPERS, IOWA 51238-0421</p>
A	2.25" WAS 2.50", 3.00" WAS 2.50" DRAWING TEMPLATE UPDATED	ADH 8/2/12	2465	APPRD. / DATE REH 3/12/09	2.) CUT FROM C06X82	
REV	DESCRIPTION	BY / DATE	CCN			
ALL DIMENSIONS ARE IN DECIMAL INCHES TOLERANCES UNLESS OTHERWISE SPECIFIED		THIRD ANGLE PROJECTION ANSI 14.5M		SHOT WEIGHT:	NOTES:	DESCRIPTION FS, 2600 GALLON TANK SKID, 6" SUPPORT CHANNEL, (HOLES)- RIGHT
POLYETHYLENE ±1% @ 68°F				SHIPPING WEIGHT:		SCALE N.S.
METAL DECIMAL ± .125" FRACTION ± 1/4" ANGLE ± 1°				FINISH:		PART NO. FS2600-SK-4

Copyright. All information furnished within this document, electronic file or design correspondence is the property of Den Hartog industries, Inc. and shall not be used, disclosed to others or copied without the expressed written consent of Den Hartog Industries, Inc.



				DRAWN / DATE ADH 9/25/07	MATERIAL 1.) SHEET, 1/4", MILD STEEL
				APPRD. / DATE REH 3/12/09	2.) SHEAR FROM S-2500
REV	DESCRIPTION	BY / DATE	CCN		
ALL DIMENSIONS ARE IN DECIMAL INCHES TOLERANCES UNLESS OTHERWISE SPECIFIED		THIRD ANGLE PROJECTION ANSI 14.5M		SHOT WEIGHT:	NOTES:
POLYETHYLENE ±1% @ 68°F	METAL DECIMAL ± .125" FRACTION ± 1/4" ANGLE ± 1°			SHIPPING WEIGHT:	
				FINISH:	



Den Hartog
INDUSTRIES, INC.

Ace Roto-Mold Injection Molding Blow Molding Sowjoy

4010 HOSPERS DRIVE S. BOX 425, HOSPERS, IOWA 51238-0421

DESCRIPTION	FS, 2600 GALLON TANK SKID, SUPPORT PLATE	
SCALE	N.S.	PART NO. FS2600-SK-5

Copyright. All information furnished within this document, electronic file or design correspondence is the property of Den Hartog industries, Inc. and shall not be used, disclosed to others or copied without the expressed written consent of Den Hartog Industries, Inc.

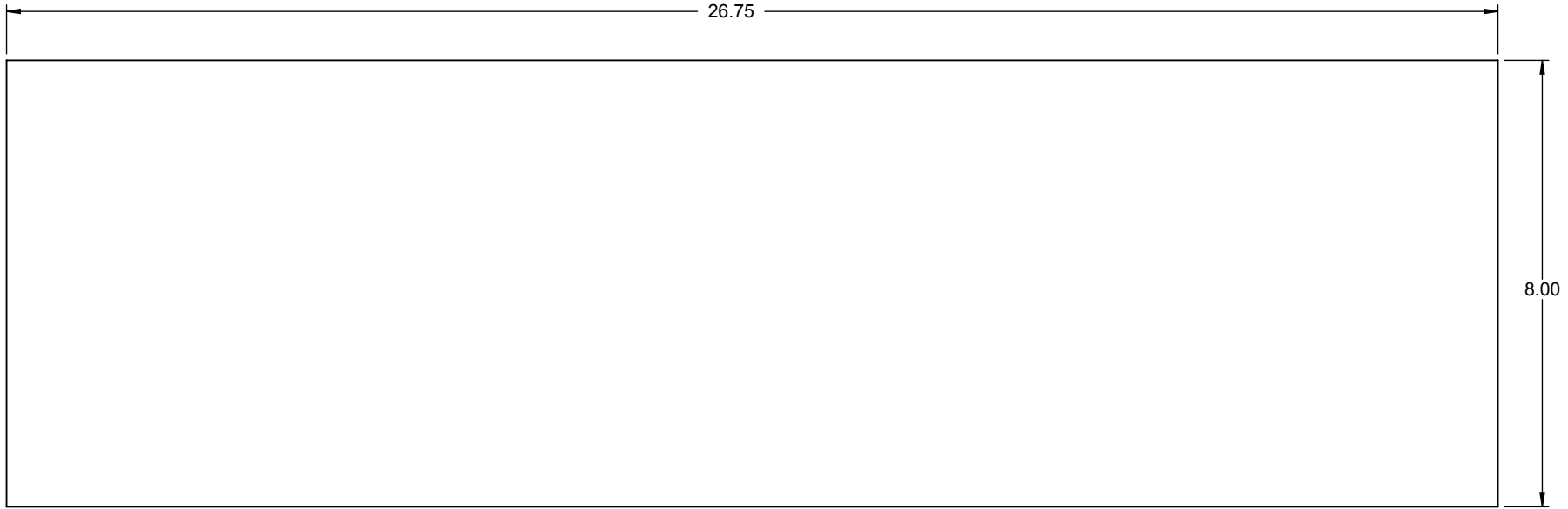

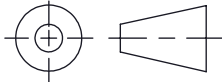
				DRAWN / DATE ADH 9/25/07	MATERIAL 1.) SHEET, 1/4", MILD STEEL	 <p>Den Hartog INDUSTRIES, INC.</p> <p>Ace Roto-Mold Injection Molding Blow Molding Sowjoy</p> <p>4010 HOSPERS DRIVE S. BOX 425, HOSPERS, IOWA 51238-0421</p>
				APPRD. / DATE REH 3/12/09	2.) SHEAR FROM S-2500	
REV	DESCRIPTION	BY / DATE	CCN			
ALL DIMENSIONS ARE IN DECIMAL INCHES TOLERANCES UNLESS OTHERWISE SPECIFIED		THIRD ANGLE PROJECTION ANSI 14.5M		SHOT WEIGHT:	NOTES:	DESCRIPTION FS, 2600 GALLON TANK SKID, SUPPORT PLATE
POLYETHYLENE ±1% @ 68°F				SHIPPING WEIGHT:		
METAL DECIMAL ± .125" FRACTION ± 1/4" ANGLE ± 1°				FINISH:		PART NO. FS2600-SK-6

Copyright. All information furnished within this document, electronic file or design correspondence is the property of Den Hartog industries, Inc. and shall not be used, disclosed to others or copied without the expressed written consent of Den Hartog Industries, Inc.

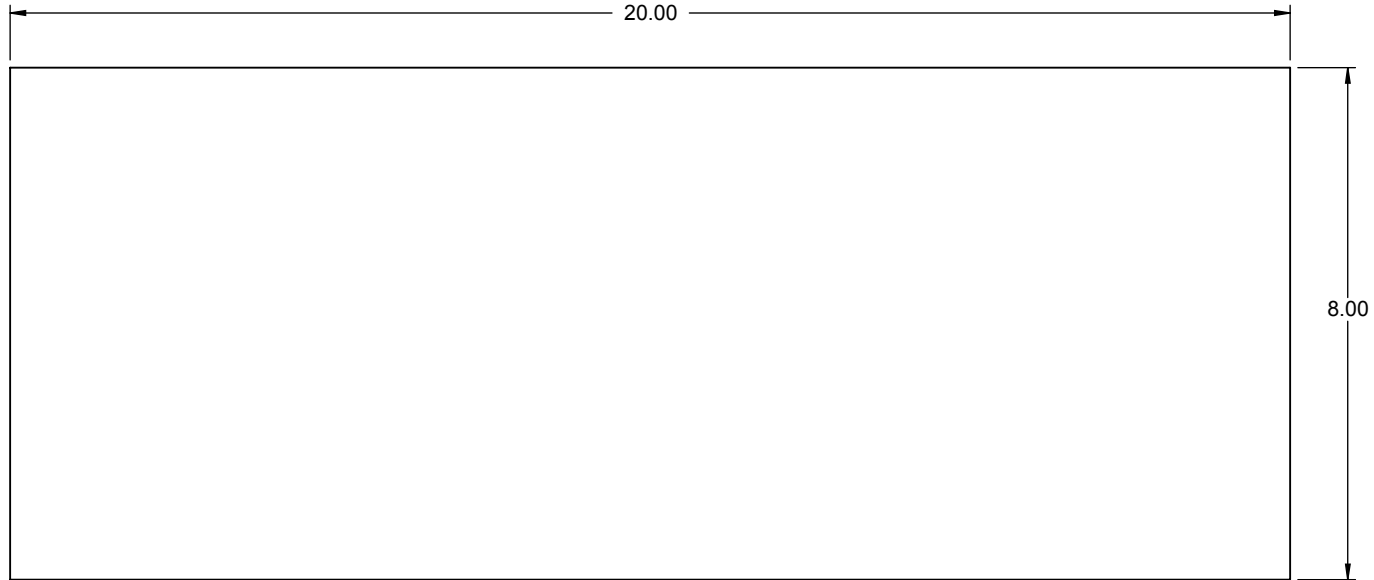

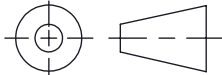
				DRAWN / DATE ADH 9/25/07	MATERIAL 1.) SHEET, 1/4", MILD STEEL	 <p>Den Hartog INDUSTRIES, INC.</p> <p>Ace Roto-Mold Injection Molding Blow Molding Sowjoy</p> <p>4010 HOSPERS DRIVE S. BOX 425, HOSPERS, IOWA 51238-0421</p>
				APPRD. / DATE REH 3/12/09	2.) SHEAR FROM S-2500	
REV	DESCRIPTION	BY / DATE	CCN			
ALL DIMENSIONS ARE IN DECIMAL INCHES TOLERANCES UNLESS OTHERWISE SPECIFIED		THIRD ANGLE PROJECTION ANSI 14.5M		SHOT WEIGHT:	NOTES:	DESCRIPTION FS, 2600 GALLON TANK SKID, SUPPORT PLATE
POLYETHYLENE ±1% @ 68°F				SHIPPING WEIGHT:		SCALE N.S.
METAL DECIMAL ± .125" FRACTION ± 1/4" ANGLE ± 1°				FINISH:		PART NO. FS2600-SK-7

Copyright. All information furnished within this document, electronic file or design correspondence is the property of Den Hartog industries, Inc. and shall not be used, disclosed to others or copied without the expressed written consent of Den Hartog Industries, Inc.

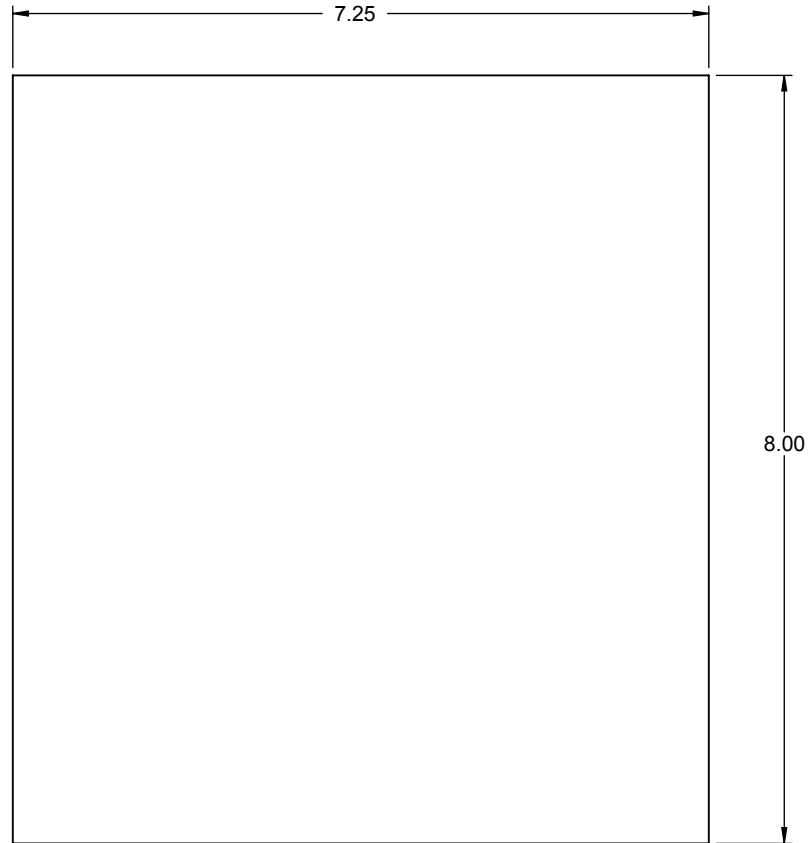

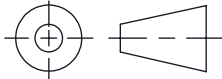
				DRAWN / DATE ADH 9/25/07	MATERIAL 1.) SHEET, 1/4", MILD STEEL	 <p>Den Hartog INDUSTRIES, INC.</p> <p>Ace Roto-Mold Injection Molding Blow Molding Sowjoy</p> <p>4010 HOSPERS DRIVE S. BOX 425, HOSPERS, IOWA 51238-0421</p>
				APPRD. / DATE REH 3/12/09	2.) SHEAR FROM S-2500	
REV	DESCRIPTION	BY / DATE	CCN			
ALL DIMENSIONS ARE IN DECIMAL INCHES TOLERANCES UNLESS OTHERWISE SPECIFIED		THIRD ANGLE PROJECTION ANSI 14.5M		SHOT WEIGHT:	NOTES:	DESCRIPTION FS, 2600 GALLON TANK SKID, SUPPORT PLATE
POLYETHYLENE ±1% @ 68°F				SHIPPING WEIGHT:		
METAL DECIMAL ± .125" FRACTION ± 1/4" ANGLE ± 1°				FINISH:		PART NO. FS2600-SK-8

Copyright. All information furnished within this document, electronic file or design correspondence is the property of Den Hartog industries, Inc. and shall not be used, disclosed to others or copied without the expressed written consent of Den Hartog Industries, Inc.

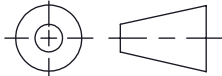

				DRAWN / DATE ADH 9/25/07	MATERIAL 1.) SHEET, 1/4", MILD STEEL	 <p>Den Hartog INDUSTRIES, INC.</p> <p>Ace Roto-Mold Injection Molding Blow Molding Sowjoy</p> <p>4010 HOSPERS DRIVE S. BOX 425, HOSPERS, IOWA 51238-0421</p>
				APPRD. / DATE REH 3/12/09	2.) SHEAR FROM S-2500	
REV	DESCRIPTION	BY / DATE	CCN			
ALL DIMENSIONS ARE IN DECIMAL INCHES TOLERANCES UNLESS OTHERWISE SPECIFIED		THIRD ANGLE PROJECTION ANSI 14.5M		SHOT WEIGHT:	NOTES:	DESCRIPTION FS, 2600 GALLON TANK SKID, SUPPORT PLATE
POLYETHYLENE ±1% @ 68°F				SHIPPING WEIGHT:		
METAL DECIMAL ± .125" FRACTION ± 1/4" ANGLE ± 1°				FINISH:		PART NO. FS2600-SK-9

Copyright. All information furnished within this document, electronic file or design correspondence is the property of Den Hartog industries, Inc. and shall not be used, disclosed to others or copied without the expressed written consent of Den Hartog Industries, Inc.



				DRAWN / DATE ADH 9/25/07	MATERIAL 1.) SHEET, 1/4", MILD STEEL
				APPRD. / DATE REH 3/12/09	2.) SHEAR FROM S-2500
REV	DESCRIPTION	BY / DATE	CCN	SHOT WEIGHT:	NOTES:
	ALL DIMENSIONS ARE IN DECIMAL INCHES TOLERANCES UNLESS OTHERWISE SPECIFIED			SHIPPING WEIGHT:	
	POLYETHYLENE ±1% @ 68°F			FINISH:	
	METAL DECIMAL ± .125" FRACTION ± 1/4" ANGLE ± 1°	THIRD ANGLE PROJECTION ANSI 14.5M			



Den Hartog
INDUSTRIES, INC.

Ace Roto-Mold Injection Molding Blow Molding Sowjoy
4010 HOSPERS DRIVE S. BOX 425, HOSPERS, IOWA 51238-0421

DESCRIPTION	FS, 2600 GALLON TANK SKID, SUPPORT PLATE	
SCALE	N.S.	PART NO. FS2600-SK-10

Copyright. All information furnished within this document, electronic file or design correspondence is the property of Den Hartog industries, Inc. and shall not be used, disclosed to others or copied without the expressed written consent of Den Hartog Industries, Inc.

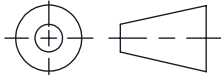

				DRAWN / DATE ADH 9/25/07	MATERIAL 1.) SHEET, 1/4", MILD STEEL	 <p>Den Hartog INDUSTRIES, INC.</p> <p>Ace Roto-Mold Injection Molding Blow Molding Sowjoy</p> <p>4010 HOSPERS DRIVE S. BOX 425, HOSPERS, IOWA 51238-0421</p>
				APPRD. / DATE REH 3/12/09	2.) SHEAR FROM S-2500	
REV	DESCRIPTION	BY / DATE	CCN			
ALL DIMENSIONS ARE IN DECIMAL INCHES TOLERANCES UNLESS OTHERWISE SPECIFIED		THIRD ANGLE PROJECTION ANSI 14.5M		SHOT WEIGHT:	NOTES:	
POLYETHYLENE ±1% @ 68°F				SHIPPING WEIGHT:		DESCRIPTION FS, 2600 GALLON TANK SKID, SUPPORT PLATE
METAL DECIMAL ± .125" FRACTION ± 1/4" ANGLE ± 1°				FINISH:		SCALE N.S. PART NO. FS2600-SK-11

Copyright. All information furnished within this document, electronic file or design correspondence is the property of Den Hartog industries, Inc. and shall not be used, disclosed to others or copied without the expressed written consent of Den Hartog Industries, Inc.

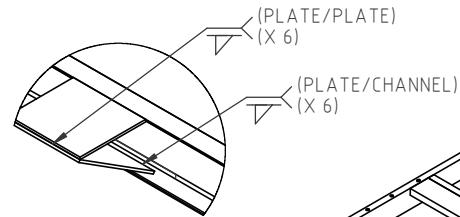

DETAIL A
SCALE 1: 15

(INNER CHANNEL/
CHANNEL)(X 12)

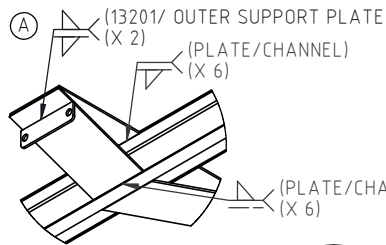
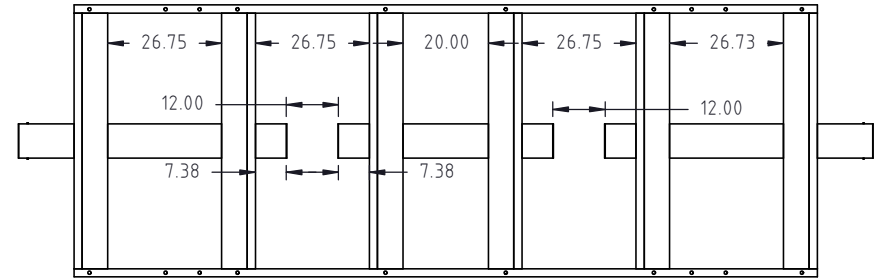
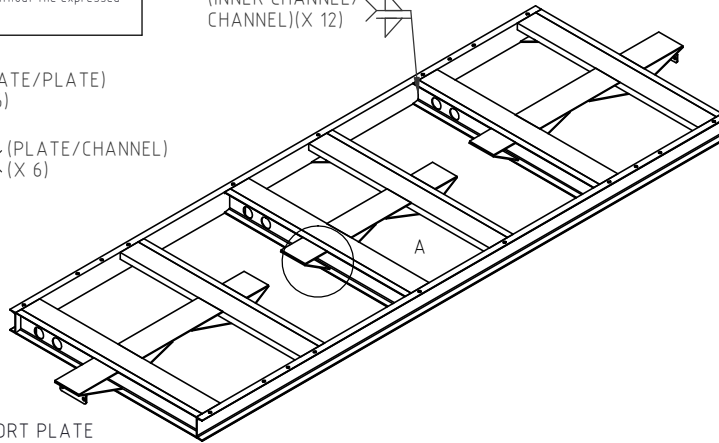

DETAIL B
SCALE 1: 22

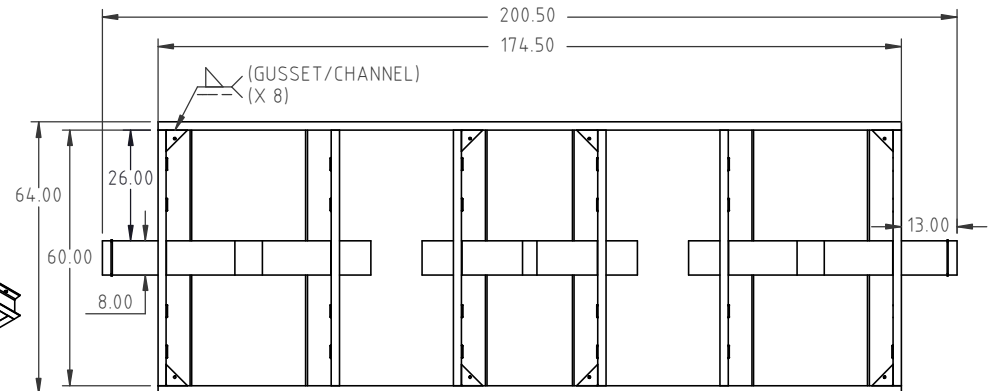
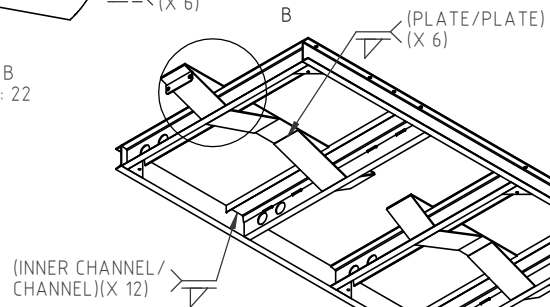

		DRAWN / DATE ADH 9/25/07		MATERIAL	
A POWDER COATING PLATE ADDED (13201) DESCRIPTION UPDATED, WEIGHT FINISH REMOVED		ADH 8/2/12	2465	APPRD. / DATE REH 3/12/09	
REV	DESCRIPTION	BY / DATE	CCN	SHOT WEIGHT:	
ALL DIMENSIONS ARE IN DECIMAL INCHES TOLERANCES UNLESS OTHERWISE SPECIFIED		THIRD ANGLE PROJECTION ANSI 14.5M		NOTES:	
POLYETHYLENE		METAL DECIMAL ± .125" FRACTION ± 1/4" ANGLE ± 1°		SHIPPING WEIGHT: (A) FINISH: (A)	
±1% @ 68°F					



Den Hartog
INDUSTRIES, INC.

Acce Roto-Mold Injection Molding Blow Molding Sowjoy

4010 HOSPERS DRIVE S. BOX 425, HOSPERS, IOWA 51238-0421

DESCRIPTION 2600 GALLON TANK SKID-WELDMENT	
SCALE N.S.	PART NO. FS2600-SK-WELDMENT